

# Pre-AP Chemistry

September 4, 2011

## 6. Periodic Table I

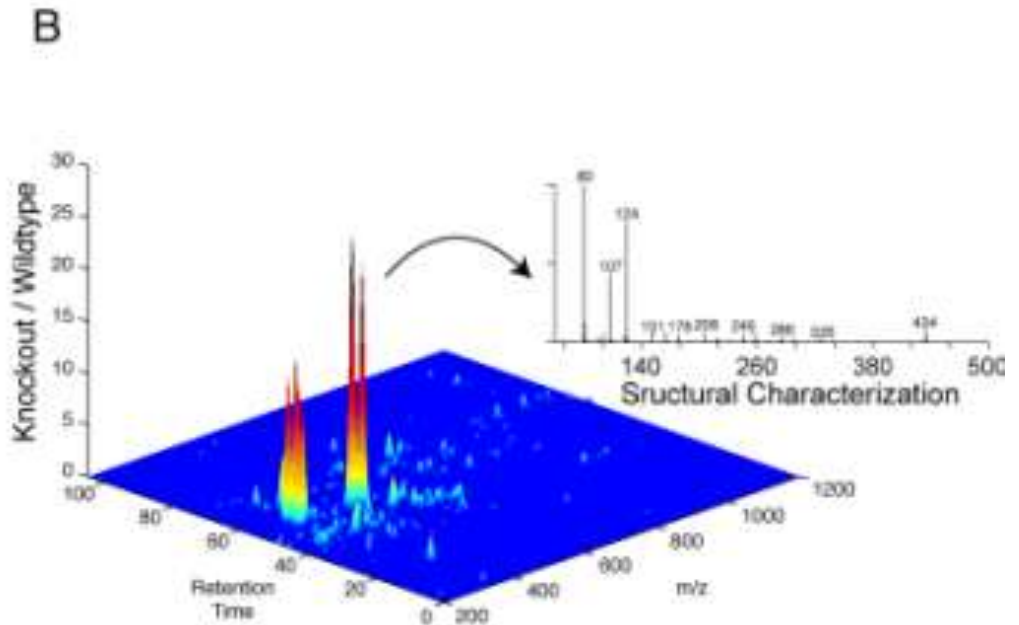

# Review

- What is the smallest unit of an element?

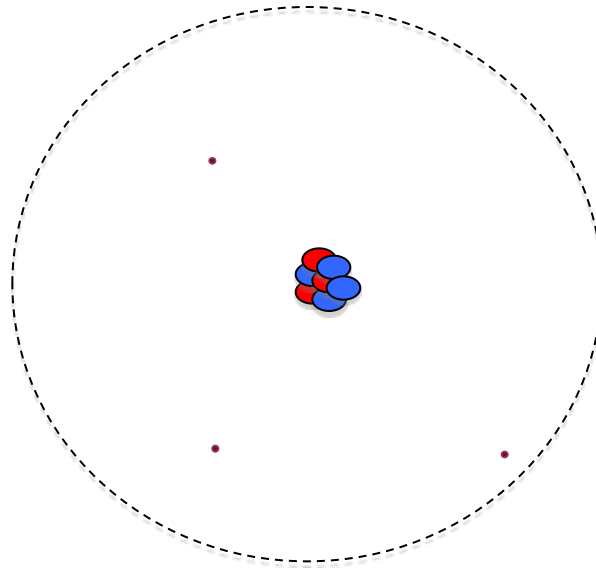

# Review

- What is the smallest unit of an element?

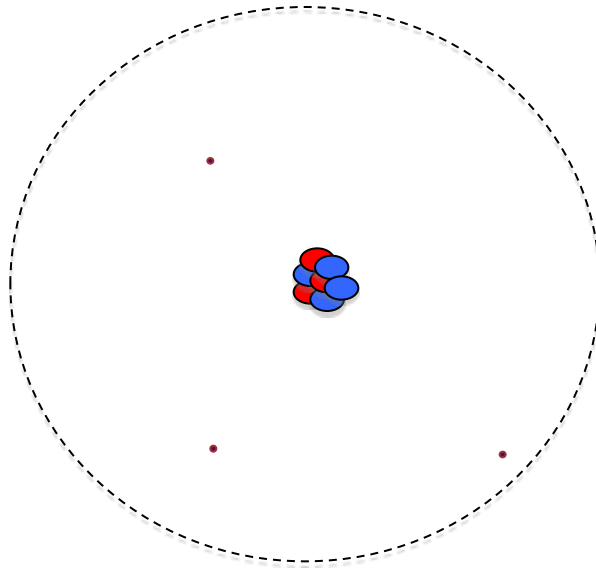

- An **atom** containing a nucleus of protons and neutrons surrounded by a 'cloud' of electrons

# Outline

- Periodic Atoms
- Mass Spectrometry
- Periodic Table: General Features

- Periodic Atoms
  - Chemical Symbol
  - Atomic Number
  - Charge
  - Atomic Mass and Isotopes
- Mass Spectrometry
  - Theory
  - Applications
- Periodic Table: General Features

# Outline

- Periodic Atoms
- Mass Spectrometry
- Periodic Table: General Features

- Periodic Atoms
  - Chemical Symbol
  - Atomic Number
  - Charge
  - Atomic Mass and Isotopes
- Mass Spectrometry
  - Theory
  - Applications
- Periodic Table: General Features

# Periodic Atoms

- Atomic symbols allow you to count the total number protons, neutrons, and electrons in an atom

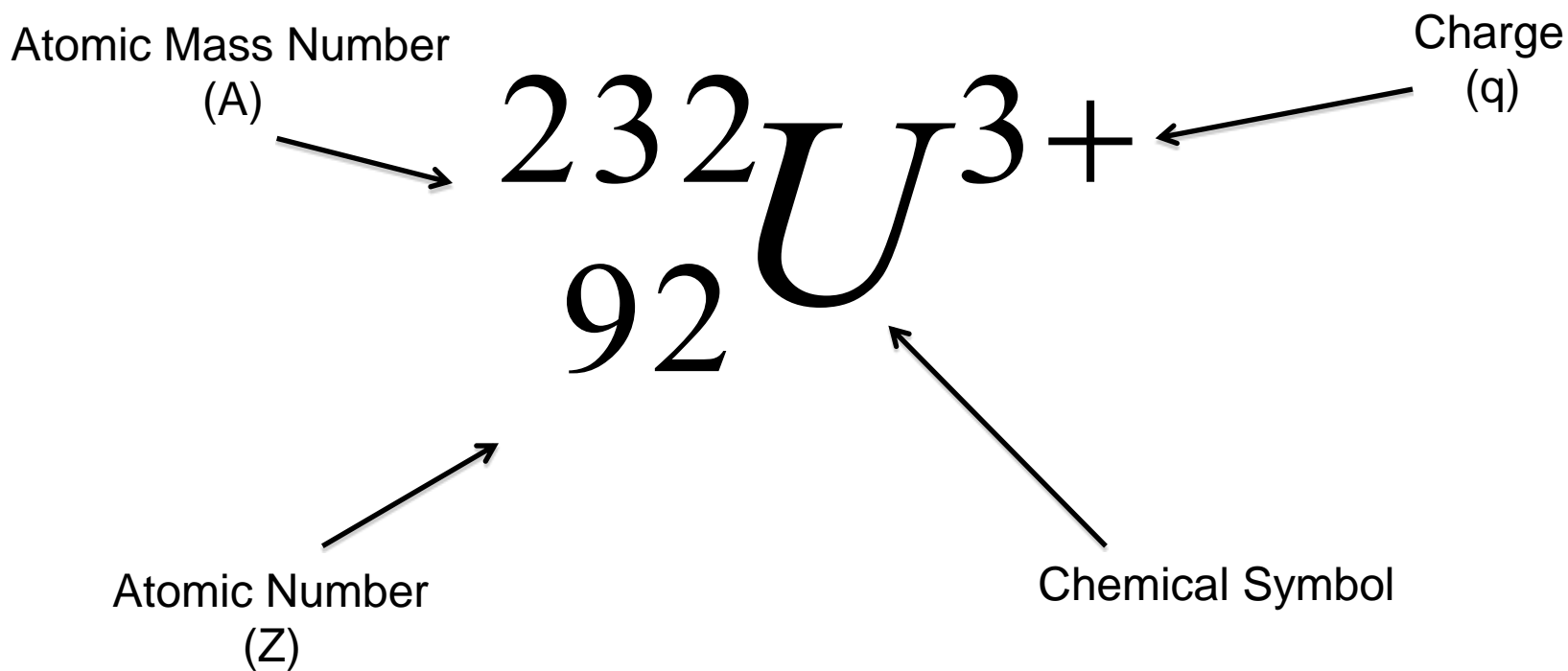

# Chemical Symbol

- A chemical symbol is a one- or two-letter abbreviation for a particular element
- Many symbols come from the Latin, Greek, Arabic, German, or French names for the elements

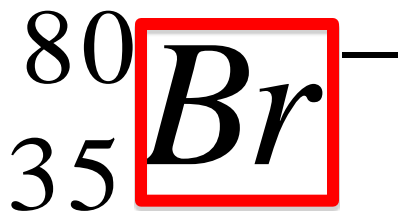

**Br**

Bromine

From French via Latin

*Dirt or stench of male goats*



# Mini Quiz

- Can you match the chemical symbol with its original meaning?

**Ar (Argon)**

**Co (Cobalt)**

**Pd (Palladium)**

**Sr (Strontium)**

**Se (Selenium)**



# Mini Quiz

- Can you match the chemical symbol with its original meaning?

**Ar (Argon)**

**Co (Cobalt)**

**Pd (Palladium)**

**Sr (Strontium)**

**Se (Selenium)**

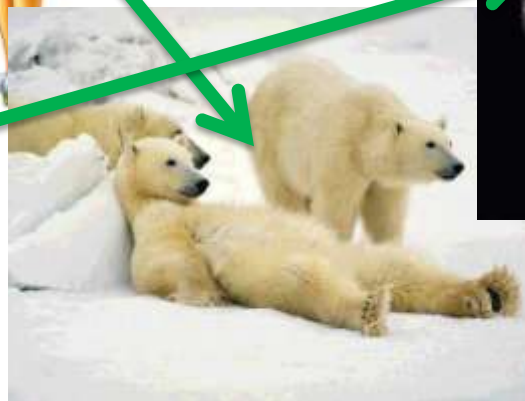

# Outline

- Periodic Atoms
- Mass Spectrometry
- Periodic Table: General Features

- Periodic Atoms
  - Chemical Symbol
  - Atomic Number
  - Charge
  - Atomic Mass and Isotopes
- Mass Spectrometry
  - Theory
  - Applications
- Periodic Table: General Features

# Atomic Number

- The number of protons in an element
- Symbolically abbreviated as 'Z'

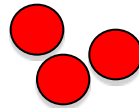

Protons (atomic number): **Z = 3**

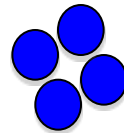

Neutrons



Electrons

+

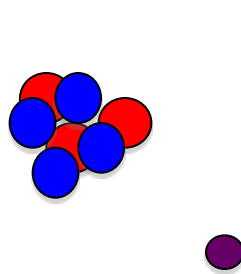
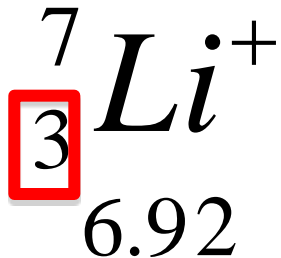

# Outline

- Periodic Atoms
- Mass Spectrometry
- Periodic Table: General Features

- Periodic Atoms
  - Chemical Symbol
  - Atomic Number
  - Charge
  - Atomic Mass and Isotopes
- Mass Spectrometry
  - Theory
  - Applications
- Periodic Table: General Features

# Charge

- The **charge** on an atom equals the **number of protons** in an atom **minus** the **number of electrons** in an atom
- For a neutral atom (# electrons = # protons), don't write charge
- For singly-charged atoms, oxidation state given by + or – without '1'

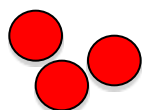

Protons

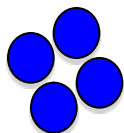

Neutrons



Electrons



3 protons



2 electrons

+

-

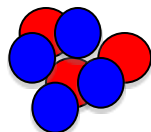

6.92



1 'extra' proton

# Charge

- An **ion** is a charged atom or molecule
- A **cation** is a **positively** charged ion (+)
- An **anion** is a **negatively** charged ion (-)

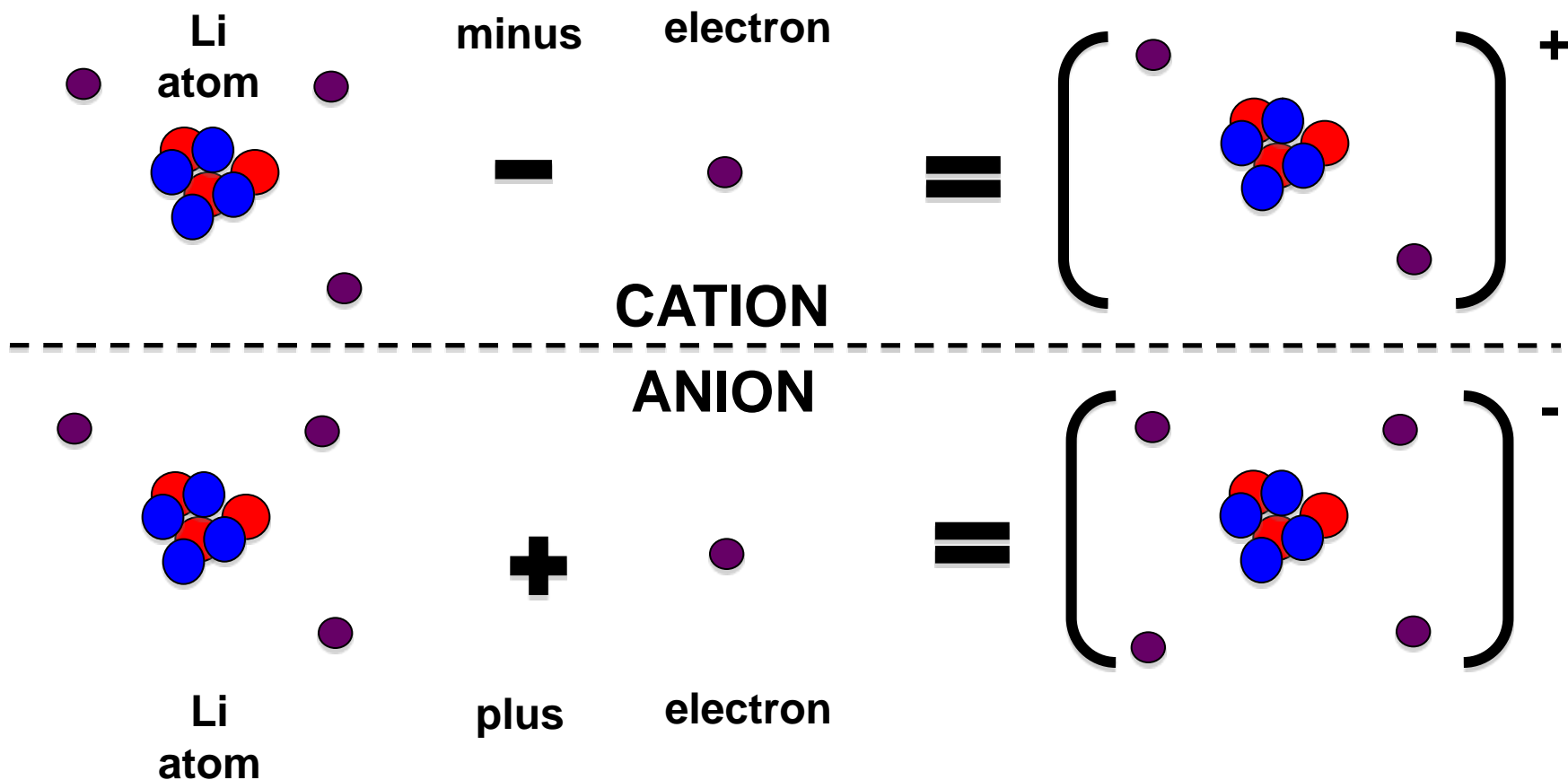

# Mini Quiz

- How many protons are in the following atoms?

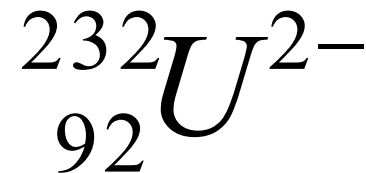
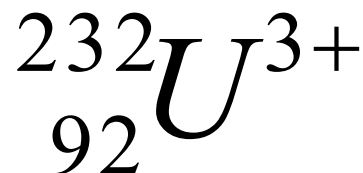

- How many electrons are in the following atoms?

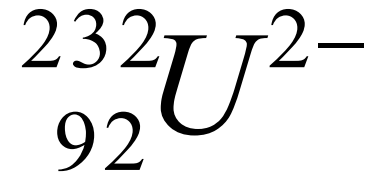
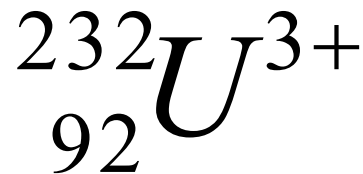
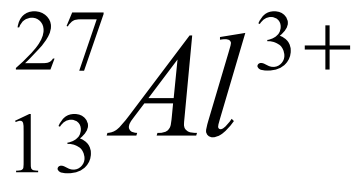

# Mini Quiz

- How many protons are in the following atoms?

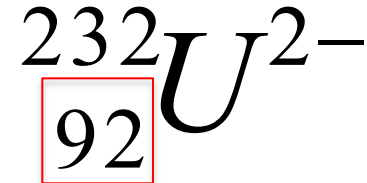
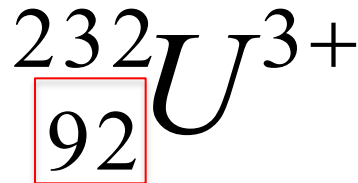
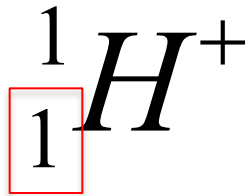

- How many electrons are in the following atoms?

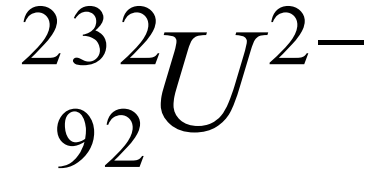
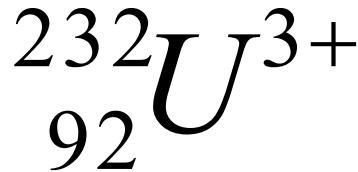
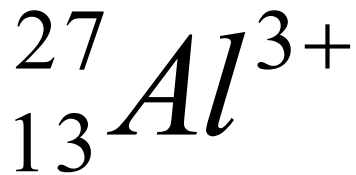

$$\begin{aligned} \# \text{ electrons} &= Z - q \\ &= 13 - 3 \end{aligned}$$

$$\# \text{ electrons} = \mathbf{10}$$

$$\begin{aligned} \# \text{ electrons} &= Z - q \\ &= 92 - 3 \end{aligned}$$

$$\# \text{ electrons} = \mathbf{89}$$

$$\begin{aligned} \# \text{ electrons} &= Z - q \\ &= 92 - (-2) \end{aligned}$$

$$\# \text{ electrons} = \mathbf{94}$$

# Outline

- Periodic Atoms
- Mass Spectrometry
- Periodic Table: General Features

- Periodic Atoms
  - Chemical Symbol
  - Atomic Number
  - Oxidation State
  - Atomic Mass and Isotopes
- Mass Spectrometry
  - Theory
  - Applications
- Periodic Table: General Features

# Atomic Mass

A hydrogen atom weighs  $1.673\text{E-}27$  kg. A carbon atom weighs  $1.993\text{E-}26$  kg. A molecule of dodecane,  $\text{C}_{12}\text{H}_{26}$ , has 26 hydrogen atoms and 12 carbon atoms. What is the mass of one molecule of dodecane?

# Atomic Mass

A hydrogen atom weighs  $1.673\text{E-}27$  kg. A carbon atom weighs  $1.993\text{E-}26$  kg. A molecule of dodecane,  $\text{C}_{12}\text{H}_{26}$ , has 26 hydrogen atoms and 12 carbon atoms. What is the mass of one molecule of dodecane?

$$m_{\text{C}_{12}\text{H}_{26}} = 12 \times m_{\text{C}} + 26 \times m_{\text{H}}$$

$$m_{\text{C}_{12}\text{H}_{26}} = 12 \times (1.993 \times 10^{-26} \text{ kg}) + 26 \times (1.673 \times 10^{-27} \text{ kg})$$

$$m_{\text{C}_{12}\text{H}_{26}} = 23.916 \times 10^{-26} \text{ kg} + 43.498 \times 10^{-27} \text{ kg}$$

$$m_{\text{C}_{12}\text{H}_{26}} = 2.435 \times 10^{-25} \text{ kg}$$

These numbers are not pretty ... There has to be a better way.

# Atomic Mass Units

- An **atomic mass unit** is the mass of carbon-12 in kg, divided by 12.
- Chemists generally talk about mass in atomic mass units.

$$m_{^{12}\text{C}} = 1.993 \times 10^{-26} \text{ kg} = 12 \text{ amu}$$

$$1 \text{ amu} = \frac{1.993 \times 10^{-26}}{12} \text{ kg}$$

# Atomic Mass Units

What does a hydrogen atom weigh in amu? Dodecane?

$$m_H = 1.673 \times 10^{-27} \text{ kg} \times \frac{12 \text{ amu}}{1.993 \times 10^{-26} \text{ kg}} = 1.007 \text{ amu}$$

$$m_{C_{12}H_{26}} = 12 \times (1.993 \times 10^{-26} \text{ kg}) + 26 \times (1.673 \times 10^{-27} \text{ kg})$$

$$m_{C_{12}H_{26}} = 12 \times (12 \text{ amu}) + 26 \times (1.007 \text{ amu})$$

$$m_{C_{12}H_{26}} = 170.182 \text{ amu}$$

From now on, we'll talk about atomic masses in terms of amu.

# Atomic Mass

- Weight of one atom of an element in atomic mass units
- Approximately equal to the total number of protons and neutrons

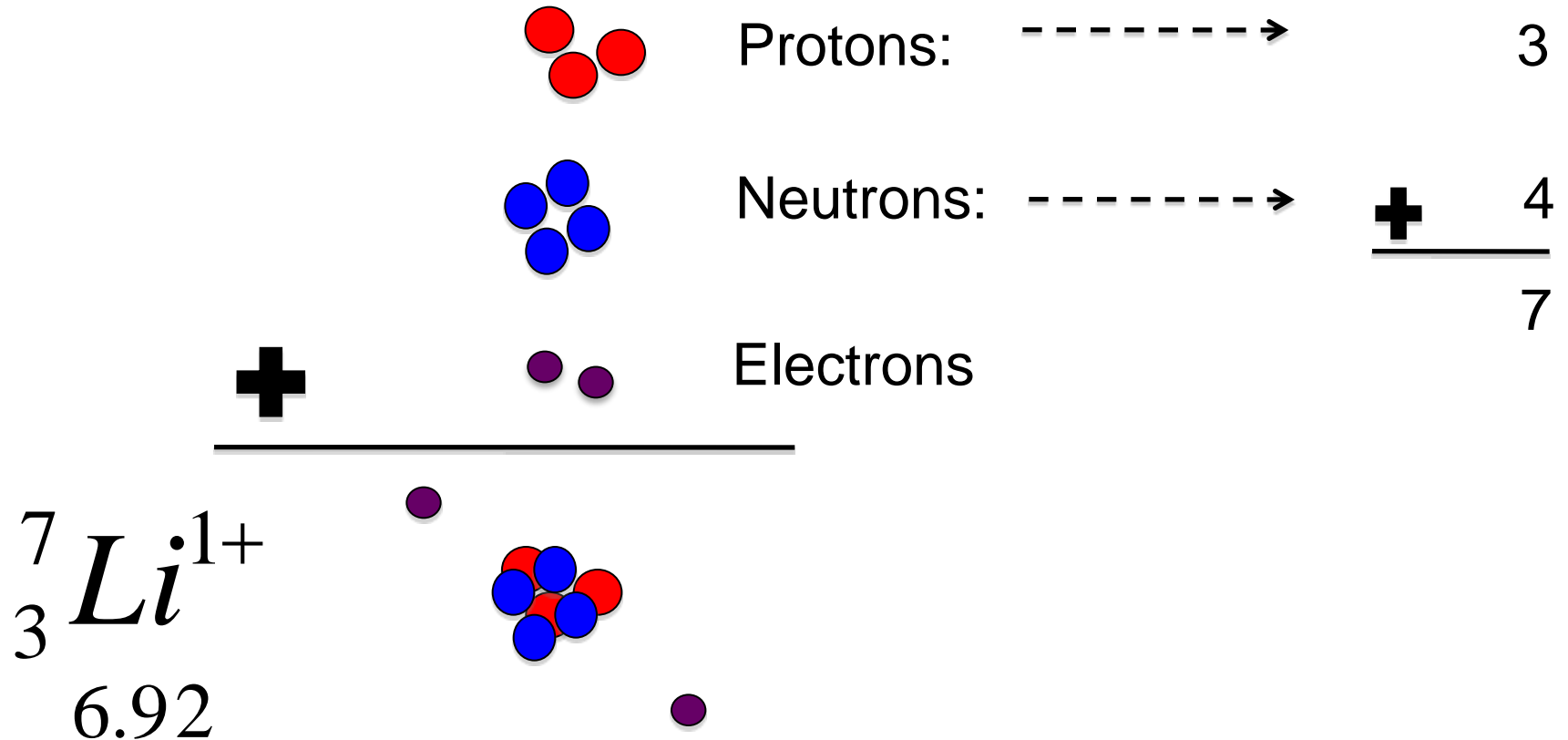

# Atomic Mass

- Weight of one atom of an element in atomic mass units
- Approximately equal to the total number of protons and neutrons

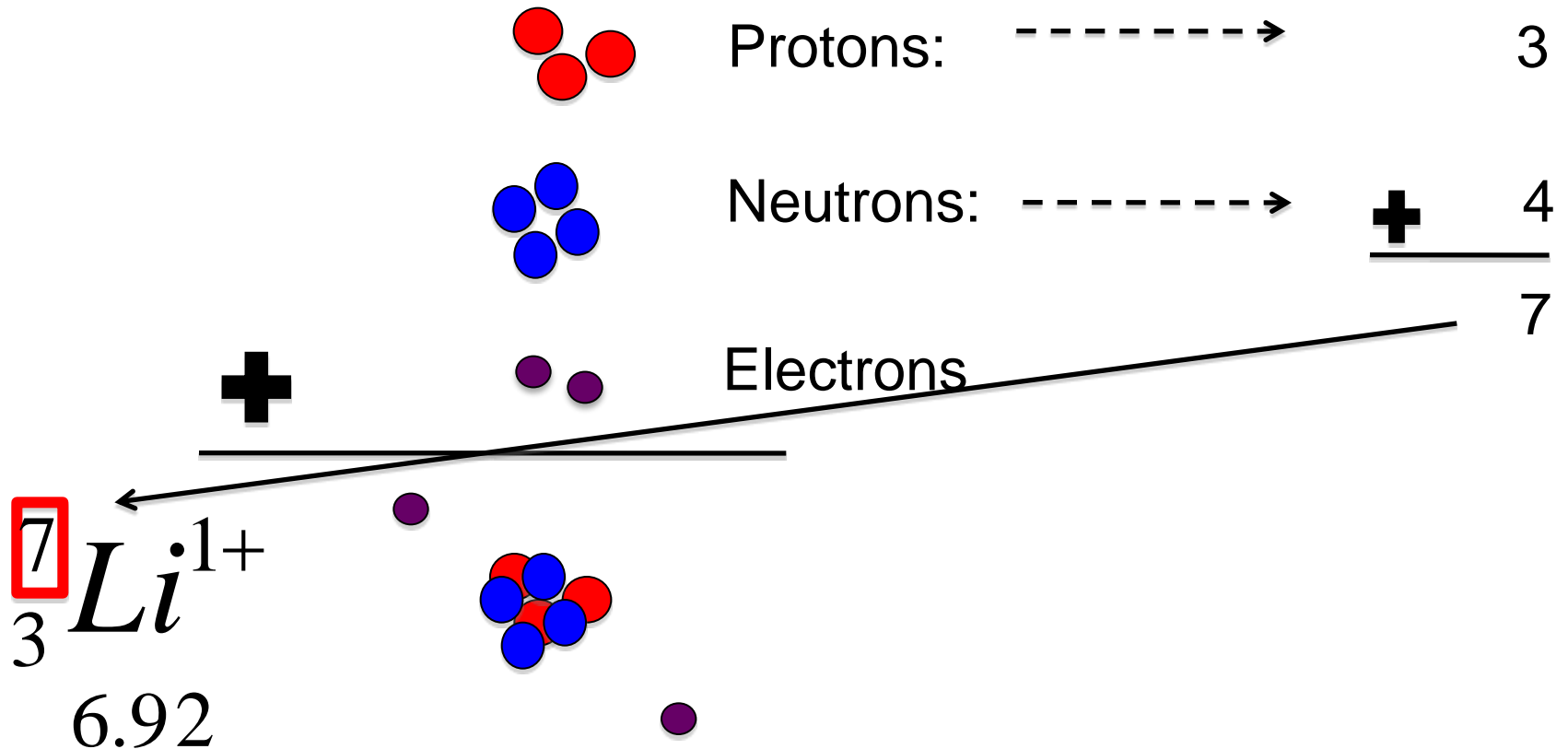

# Isotopes

- **Isotopes** are different atoms of an element with the **same number of protons** but **different numbers of neutrons**
- An element's atomic mass is the **weighted mass** of all of that element's isotopes

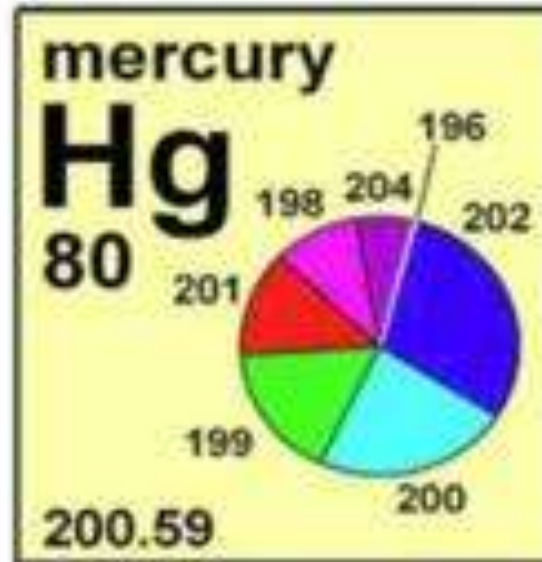

# Isotopes

- **Isotopes** are different atoms of an element with the same number of protons but **different numbers of neutrons**
- An element's atomic mass is the **weighted mass** of all of that element's isotopes

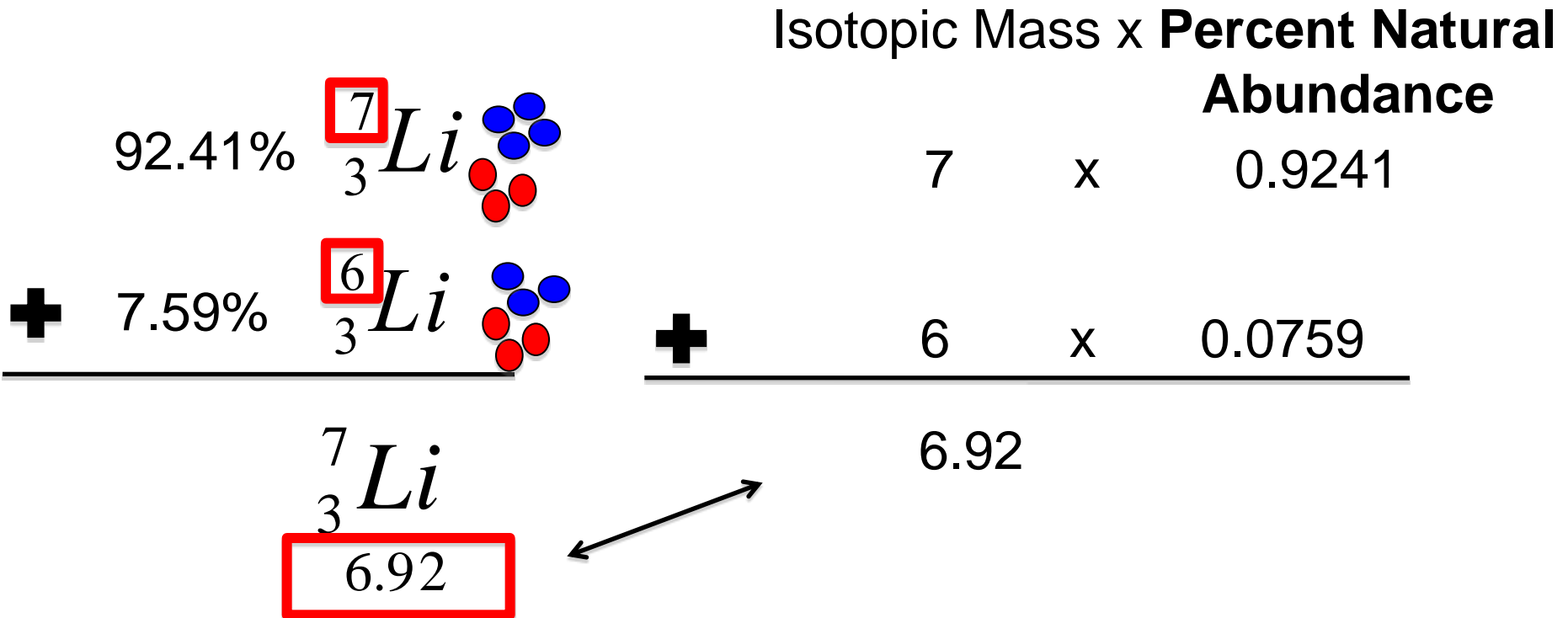

# Mini Quiz

- Fe (iron) has three isotopes with masses 56, 54, and 57. How many protons and neutrons are in each isotope?
- What is the weighted mass of Fe? Its isotopes, 56, 54, and 57, have percent natural abundances of 92%, 6% and 2%, respectively.
- The weighted mass of C (carbon) is 12.011, and it has only two isotopes, 12 and 13. What is the percent natural abundance of each of these two isotopes?

# Mini Quiz

- Fe (iron) has three isotopes with masses 56, 54, and 57. How many protons and neutrons are in each isotope?

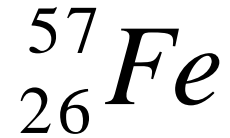
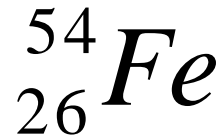
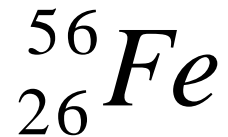

Protons

26

26

26

Neutrons

30

28

31

# Mini Quiz

- What is the weighted mass of Fe? Its isotopes, 56, 54, and 57, have percent natural abundances of 92%, 6% and 2%, respectively.

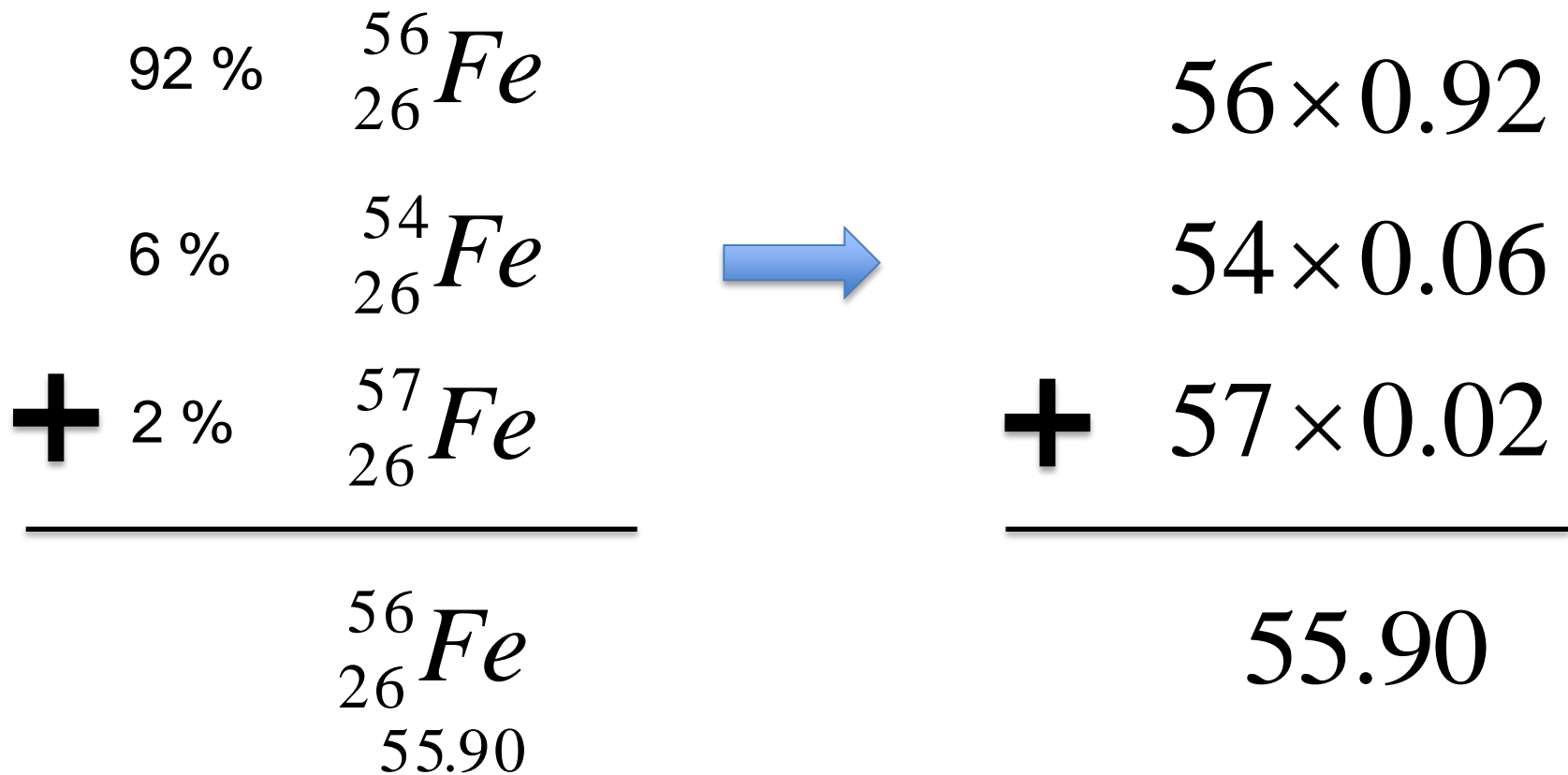

# Mini Quiz

- The weighted mass of C (carbon) is 12.011, and it has only two isotopes, 12 and 13. What is the percent natural abundance of each of these two isotopes?

$$m_{\text{C}} = m_{^{12}\text{C}} \times (\% ^{12}\text{C}) + m_{^{13}\text{C}} \times (\% ^{13}\text{C})$$

12.011

$$1 = \% ^{12}\text{C} + \% ^{13}\text{C}$$

$$12.011 \text{amu} = (12 \text{amu}) \times (\% ^{12}\text{C}) + (13 \text{amu}) \times (1 - \% ^{12}\text{C})$$

$$\% ^{12}\text{C} = 0.989$$

$$\% ^{13}\text{C} = 0.011$$

# Outline

- Periodic Atoms
- Mass Spectrometry
- Periodic Table: General Features

- Periodic Atoms
  - Chemical Symbol
  - Atomic Number
  - Charge
  - Atomic Mass and Isotopes
- Mass Spectrometry
  - Theory
  - Applications
- Periodic Table: General Features

# Isotopic Masses

- How do scientists determine all of the isotopes of an element?
- Recall Thompson's cathode ray experiments – any ideas?

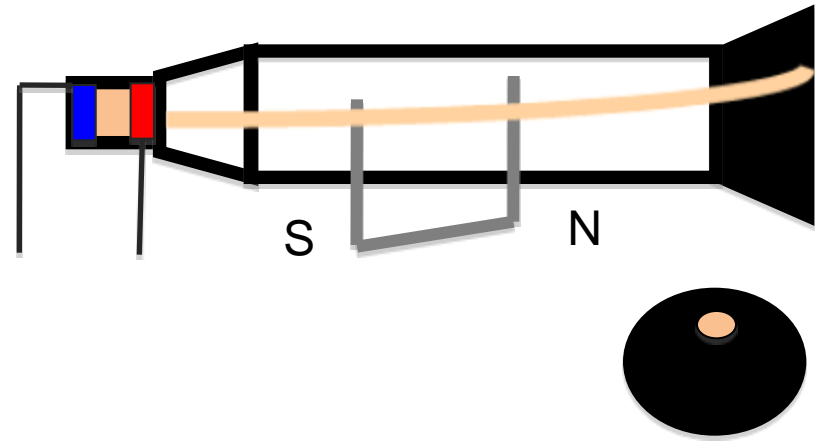
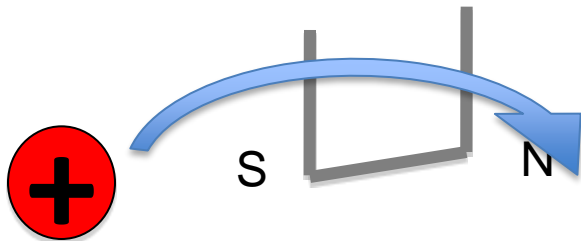
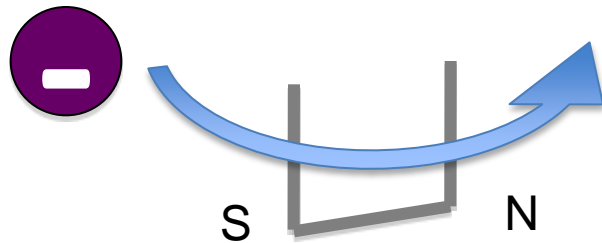

- What did Thompson discover in his experiments?

# Isotopic Masses

- How do scientists determine all of the isotopes of an element?
- Recall Thompson's cathode ray experiments – any ideas?

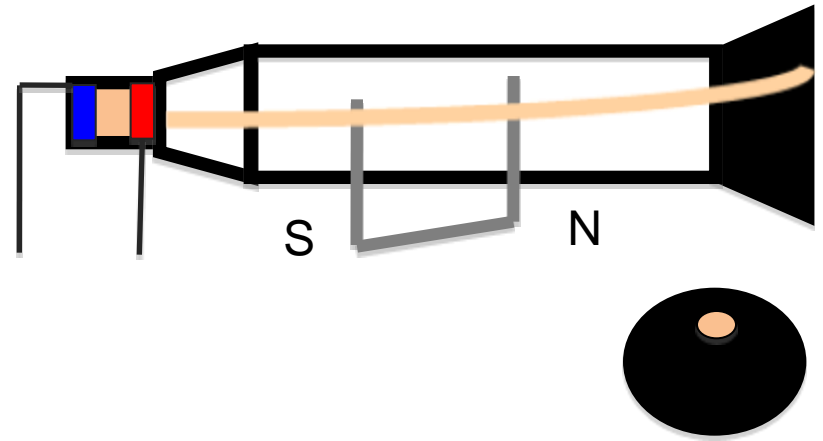
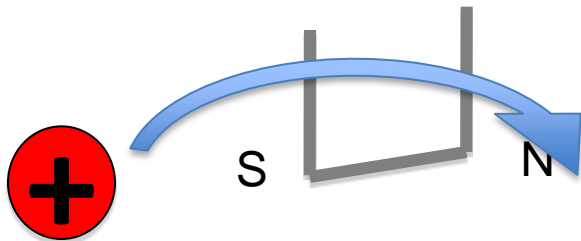
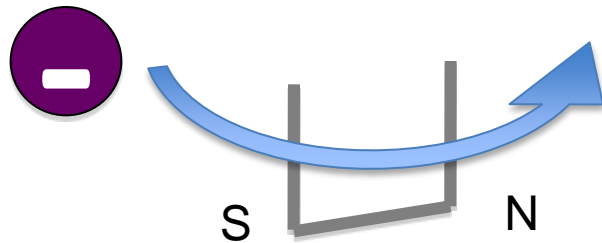

- What did Thompson discover in his experiments?

The **mass-to-charge ratio** of the electron.

# Principle of a Mass Spectrometer

- **Mass spectrometers** use electric and magnetic fields to measure the **mass-to-charge ratio** of different ions

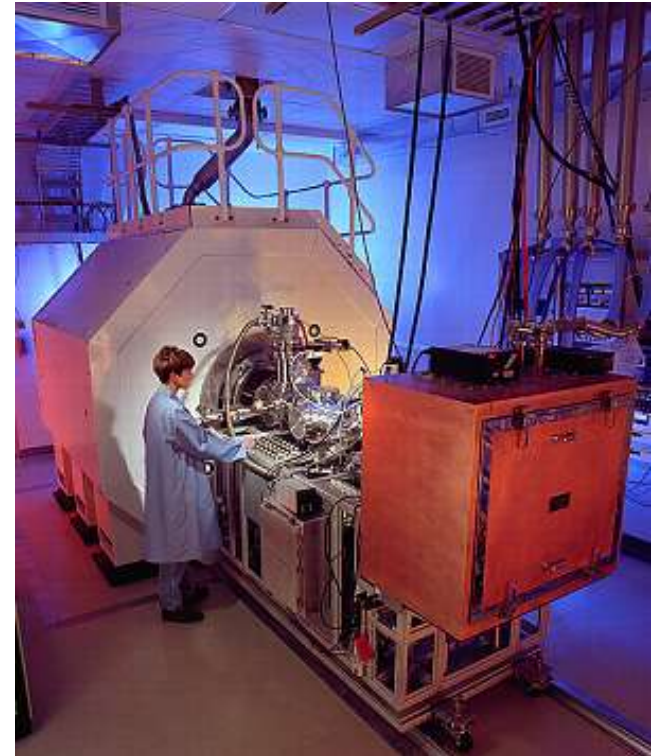
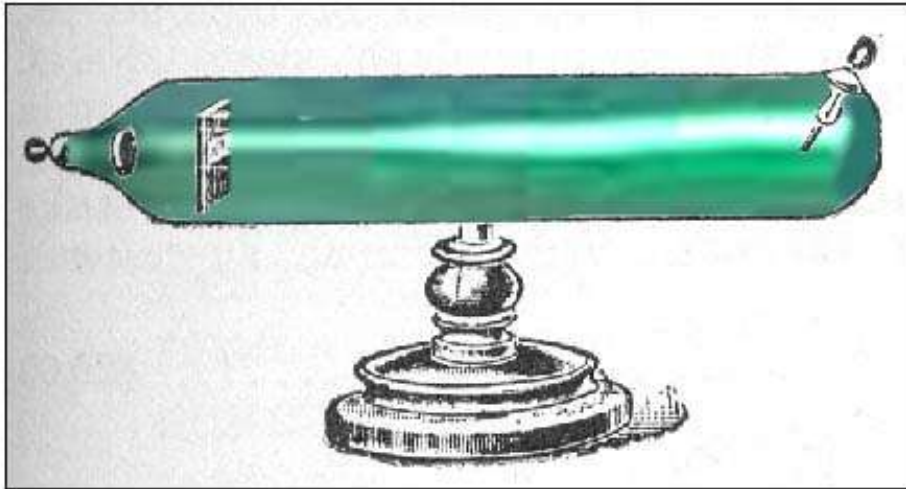

For a given set of electric and magnetic fields, the path an ion follows only depends on the ratio of its charge and its mass!

# Principle of a Mass Spectrometer

For a given set of electric and magnetic fields, the path an ion follows only depends on the ratio of its charge and its mass!

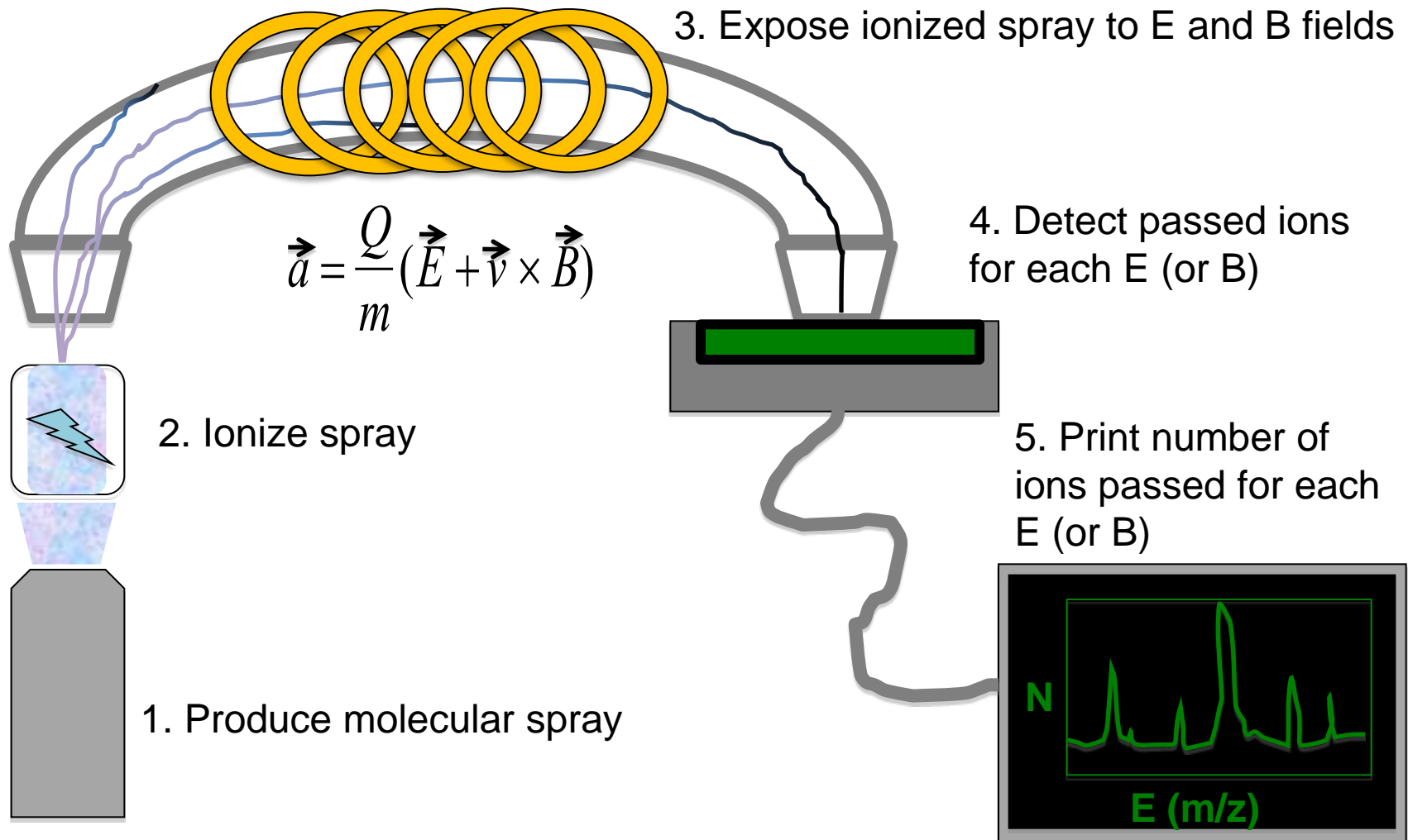

# Principle of a Mass Spectrometer

1. Produce molecular spray

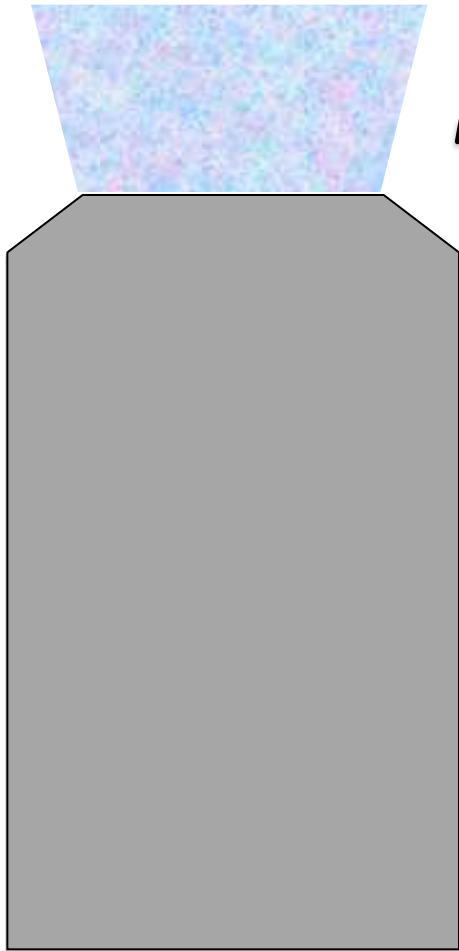

2. Ionize spray

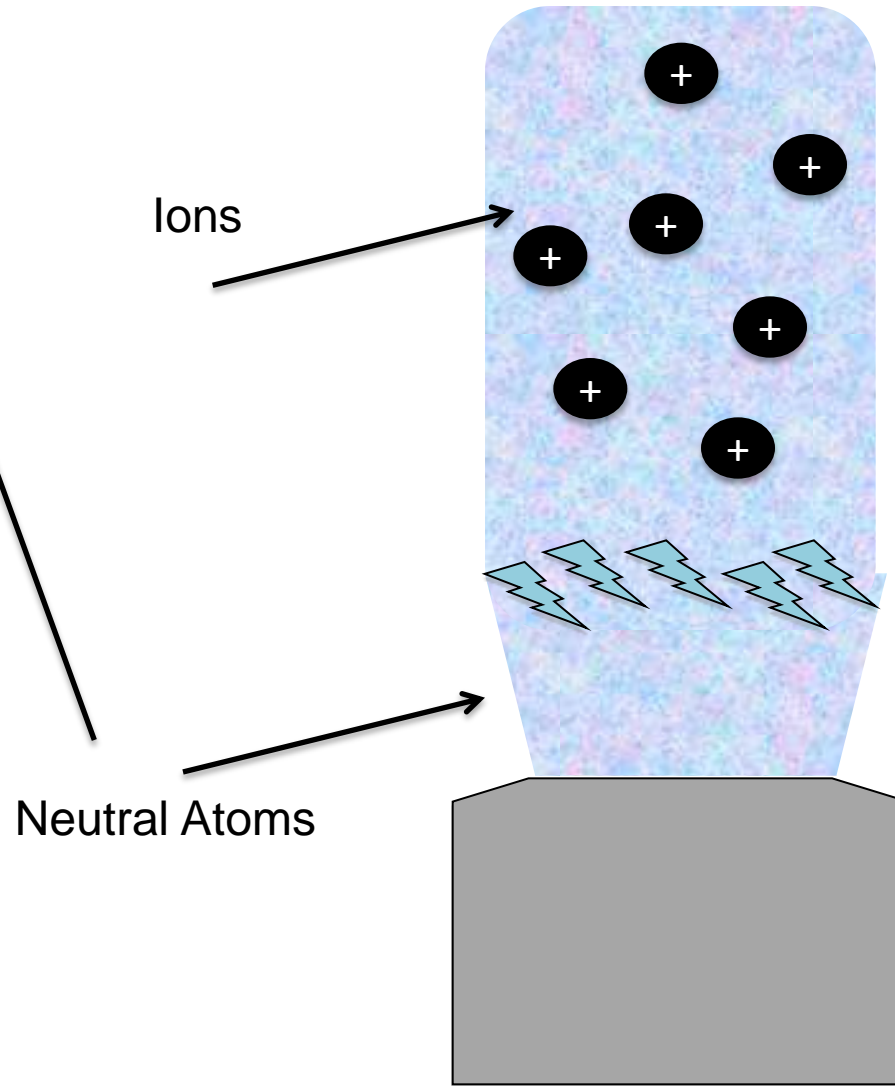

# Principle of a Mass Spectrometer

3. Expose ionized spray to electric and magnetic fields

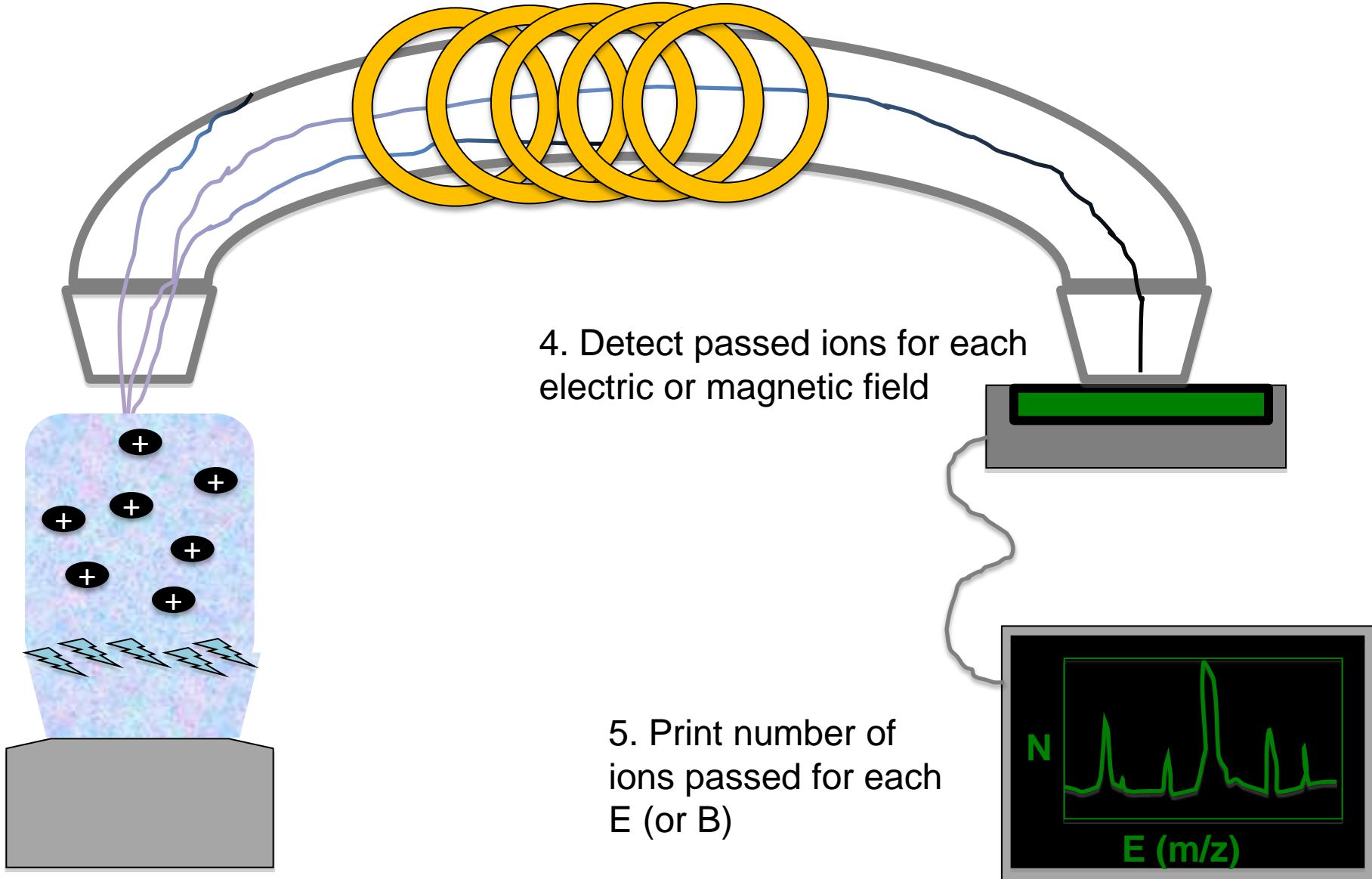

# Applications

- Mass spectrometry is used to determine percent natural abundance of elemental isotopes

$^{132}_{54}\text{Xe}$   
131.3879

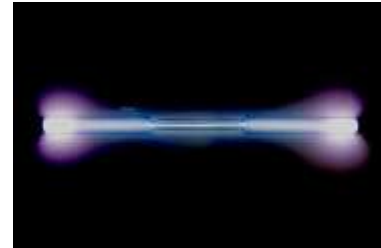
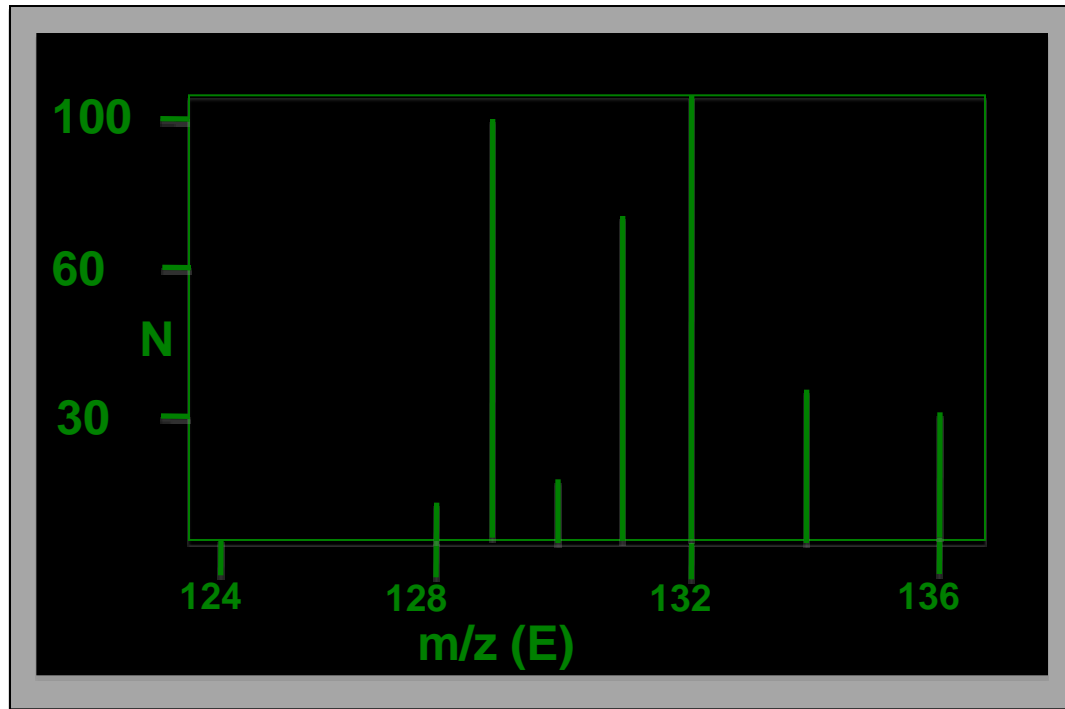

# Outline

- Periodic Atoms
- Mass Spectrometry
- Periodic Table: General Features

- Periodic Atoms
  - Chemical Symbol
  - Atomic Number
  - Charge
  - Atomic Mass and Isotopes
- Mass Spectrometry
  - Theory
  - Applications
- Periodic Table: General Features

# Periodic Table

- Rows (periods) vs Columns (groups, families)

	1	2	3	4	5	6	7	8	9	10	11	12	13	14	15	16	17	18
1	hydrogen 1 <b>H</b> 1.0079																	helium 2 <b>He</b> 4.0026
2	lithium 3 <b>Li</b> 6.941	beryllium 4 <b>Be</b> 9.0122											boron 5 <b>B</b> 10.811	carbon 6 <b>C</b> 12.011	nitrogen 7 <b>N</b> 14.007	oxygen 8 <b>O</b> 15.999	fluorine 9 <b>F</b> 18.998	neon 10 <b>Ne</b> 20.180
3	sodium 11 <b>Na</b> 22.990	magnesium 12 <b>Mg</b> 24.305											aluminum 13 <b>Al</b> 26.982	silicon 14 <b>Si</b> 28.086	phosphorus 15 <b>P</b> 30.974	sulfur 16 <b>S</b> 32.065	chlorine 17 <b>Cl</b> 35.453	argon 18 <b>Ar</b> 39.948
4	potassium 19 <b>K</b> 39.098	calcium 20 <b>Ca</b> 40.078	scandium 21 <b>Sc</b> 44.956	titanium 22 <b>Ti</b> 47.867	vanadium 23 <b>V</b> 50.942	chromium 24 <b>Cr</b> 51.996	manganese 25 <b>Mn</b> 54.938	iron 26 <b>Fe</b> 55.845	cobalt 27 <b>Co</b> 58.933	nickel 28 <b>Ni</b> 58.693	copper 29 <b>Cu</b> 63.546	zinc 30 <b>Zn</b> 65.38	gallium 31 <b>Ga</b> 69.723	germanium 32 <b>Ge</b> 72.61	arsenic 33 <b>As</b> 74.922	selecnium 34 <b>Se</b> 78.96	bromine 35 <b>Br</b> 79.904	krypton 36 <b>Kr</b> 83.80
5	rubidium 37 <b>Rb</b> 85.468	strontium 38 <b>Sr</b> 87.62	yttrium 39 <b>Y</b> 88.906	zirconium 40 <b>Zr</b> 91.224	niobium 41 <b>Nb</b> 92.906	molybdenum 42 <b>Mo</b> 95.94	technetium 43 <b>Tc</b> [98]	ruthenium 44 <b>Ru</b> 101.07	rhodium 45 <b>Rh</b> 102.91	palladium 46 <b>Pd</b> 106.42	silver 47 <b>Ag</b> 107.87	cadmium 48 <b>Cd</b> 112.41	indium 49 <b>In</b> 114.82	tin 50 <b>Sn</b> 118.71	antimony 51 <b>Sb</b> 121.76	tellurium 52 <b>Te</b> 127.60	iodine 53 <b>I</b> 126.90	xenon 54 <b>Xe</b> 131.29
6	caesium 55 <b>Cs</b> 132.91	barium 56 <b>Ba</b> 137.33	lanthanum 57-70 *	hafnium 71 <b>Hf</b> 178.49	tantalum 72 <b>Ta</b> 180.95	wolfram 73 <b>W</b> 183.84	reynoldsium 74 <b>Re</b> 186.21	osmium 75 <b>Os</b> 190.23	iridium 76 <b>Ir</b> 192.22	platinum 77 <b>Pt</b> 195.08	gold 78 <b>Au</b> 196.97	mercury 79 <b>Hg</b> 200.59	thallium 80 <b>Tl</b> 204.38	lead 81 <b>Pb</b> 207.2	bismuth 82 <b>Bi</b> 208.98	polonium 83 <b>Po</b> [209]	astatine 84 <b>At</b> [210]	radon 85 <b>Rn</b> [222]
7	francium 87 <b>Fr</b> [223]	radium 88 <b>Ra</b> [226]	actinium 89-102 **	lawrencium 103 <b>Lr</b> [262]	rutherfordium 104 <b>Rf</b> [261]	dubnium 105 <b>Db</b> [262]	seaborgium 106 <b>Sg</b> [263]	bohrium 107 <b>Bh</b> [264]	hassium 108 <b>Hs</b> [265]	meitnerium 109 <b>Mt</b> [266]	unnilium 110 <b>Uun</b> [271]	ununium 111 <b>Uuu</b> [272]	unbinium 112 <b>Uub</b> [277]	ununseptium 113 <b>Uus</b> [283]	ununoctium 114 <b>Uuq</b> [289]			

Columns

Rows

\* Lanthanide series

lanthanum 57 <b>La</b> 138.91	cerium 58 <b>Ce</b> 140.12	praseodymium 59 <b>Pr</b> 140.91	neodymium 60 <b>Nd</b> 144.24	promethium 61 <b>Pm</b> [145]	samarium 62 <b>Sm</b> 150.36	europium 63 <b>Eu</b> 151.96	gadolinium 64 <b>Gd</b> 157.25	terbium 65 <b>Tb</b> 158.93	dysprosium 66 <b>Dy</b> 162.50	holmium 67 <b>Ho</b> 164.93	erbium 68 <b>Er</b> 167.26	thulium 69 <b>Tm</b> 168.93	ytterbium 70 <b>Yb</b> 173.04
--	-------------------------------------	---	--	--	---------------------------------------	---------------------------------------	---	--------------------------------------	---	--------------------------------------	-------------------------------------	--------------------------------------	--

\*\* Actinide series

actinium 89 <b>Ac</b> [227]	thorium 90 <b>Th</b> 232.04	protactinium 91 <b>Pa</b> 231.04	uranium 92 <b>U</b> 238.03	neptunium 93 <b>Np</b> [237]	plutonium 94 <b>Pu</b> [244]	americium 95 <b>Am</b> [243]	curium 96 <b>Cm</b> [247]	berkelium 97 <b>Bk</b> [247]	californium 98 <b>Cf</b> [251]	einsteinium 99 <b>Es</b> [252]	fermium 100 <b>Fm</b> [257]	mendeleevium 101 <b>Md</b> [258]	nobelium 102 <b>No</b> [259]
--------------------------------------	--------------------------------------	---	-------------------------------------	---------------------------------------	---------------------------------------	---------------------------------------	------------------------------------	---------------------------------------	---	---	--------------------------------------	---	---------------------------------------

# Periodic Table

- Special Groups: What properties do the elements in each have in common? What is the origin of these common properties?

	1	2	3	4	5	6	7	8	9	10	11	12	13	14	15	16	17	18												
1	<b>H</b> Hydrogen 1.00794	Atomic # Symbol Name Atomic Mass																2	<b>He</b> Helium 4.002602											
2	<b>Li</b> Lithium 6.941	<b>Be</b> Beryllium 9.012182																	3	<b>B</b> Boron 10.811	4	<b>C</b> Carbon 12.0107	5	<b>N</b> Nitrogen 14.0067	6	<b>O</b> Oxygen 15.9994	7	<b>F</b> Fluorine 18.9984032	8	<b>Ne</b> Neon 20.1797
3	<b>Na</b> Sodium 22.98976928	<b>Mg</b> Magnesium 24.3050																	9	<b>Al</b> Aluminum 26.9815386	10	<b>Si</b> Silicon 28.0855	11	<b>P</b> Phosphorus 30.973762	12	<b>S</b> Sulfur 32.065	13	<b>Cl</b> Chlorine 35.453	14	<b>Ar</b> Argon 39.948
4	<b>K</b> Potassium 39.0983	<b>Ca</b> Calcium 40.078	<b>Sc</b> Scandium 44.955912	<b>Ti</b> Titanium 47.867	<b>V</b> Vanadium 50.9415	<b>Cr</b> Chromium 51.9961	<b>Mn</b> Manganese 54.938045	<b>Fe</b> Iron 55.845	<b>Co</b> Cobalt 58.933195	<b>Ni</b> Nickel 58.6934	<b>Cu</b> Copper 63.546	<b>Zn</b> Zinc 65.38	<b>Ga</b> Gallium 69.723	<b>Ge</b> Germanium 72.64	<b>As</b> Arsenic 74.92160	<b>Se</b> Selenium 78.96	<b>Br</b> Bromine 79.904	<b>Kr</b> Krypton 83.798												
5	<b>Rb</b> Rubidium 85.4678	<b>Sr</b> Strontium 87.62	<b>Y</b> Yttrium 88.90585	<b>Zr</b> Zirconium 91.224	<b>Nb</b> Niobium 92.90638	<b>Mo</b> Molybdenum 95.96	<b>Tc</b> Technetium (97.9072)	<b>Ru</b> Ruthenium 101.07	<b>Rh</b> Rhodium 102.90550	<b>Pd</b> Palladium 106.42	<b>Ag</b> Silver 107.8682	<b>Cd</b> Cadmium 112.411	<b>In</b> Indium 114.818	<b>Sn</b> Tin 118.710	<b>Sb</b> Antimony 121.760	<b>Te</b> Tellurium 127.60	<b>I</b> Iodine 126.90447	<b>Xe</b> Xenon 131.293												
6	<b>Cs</b> Cesium 132.9054519	<b>Ba</b> Barium 137.327	57-71	<b>Hf</b> Hafnium 178.49	<b>Ta</b> Tantalum 180.94788	<b>W</b> Tungsten 183.84	<b>Re</b> Rhenium 186.207	<b>Os</b> Osmium 190.23	<b>Ir</b> Iridium 192.222	<b>Pt</b> Platinum 195.084	<b>Au</b> Gold 196.966569	<b>Hg</b> Mercury 200.59	<b>Tl</b> Thallium 204.3833	<b>Pb</b> Lead 207.2	<b>Bi</b> Bismuth 208.98040	<b>Po</b> Polonium (209)	<b>At</b> Astatine (209)	<b>Rn</b> Radon (222)												
7	<b>Fr</b> Francium (223)	<b>Ra</b> Radium (226)	89-103	<b>Rf</b> Rutherfordium (261)	<b>Db</b> Dubnium (262)	<b>Sg</b> Seaborgium (266)	<b>Bh</b> Bohrium (264)	<b>Hs</b> Hassium (277)	<b>Mt</b> Meitnerium (268)	<b>Ds</b> Darmstadtium (271)	<b>Rg</b> Roentgenium (272)	<b>Uub</b> Ununbium (285)	<b>Uut</b> Ununtrium (284)	<b>Uuq</b> Ununquadium (289)	<b>Uup</b> Ununpentium (288)	<b>Uuh</b> Ununhexium (292)	<b>Uus</b> Ununseptium	<b>Uuo</b> Ununoctium (294)												

For elements with no stable isotopes, the mass number of the isotope with the longest half-life is in parentheses.

Periodic Table Design and Interface Copyright © 1997 Michael Dayah. <http://www.ptable.com/> Last updated: May 27, 2008



57	58	59	60	61	62	63	64	65	66	67	68	69	70	71
<b>La</b> Lanthanum 138.90547	<b>Ce</b> Cerium 140.116	<b>Pr</b> Praseodymium 140.90765	<b>Nd</b> Neodymium 144.242	<b>Pm</b> Promethium (145)	<b>Sm</b> Samarium 150.36	<b>Eu</b> Europium 151.964	<b>Gd</b> Gadolinium 157.25	<b>Tb</b> Terbium 158.92535	<b>Dy</b> Dysprosium 162.500	<b>Ho</b> Holmium 164.93032	<b>Er</b> Erbium 167.259	<b>Tm</b> Thulium 168.93421	<b>Yb</b> Ytterbium 173.054	<b>Lu</b> Lutetium 174.9668
89	90	91	92	93	94	95	96	97	98	99	100	101	102	103
<b>Ac</b> Actinium (227)	<b>Th</b> Thorium 232.03806	<b>Pa</b> Protactinium 231.03688	<b>U</b> Uranium 238.02891	<b>Np</b> Neptunium (237)	<b>Pu</b> Plutonium (244)	<b>Am</b> Americium (243)	<b>Cm</b> Curium (247)	<b>Bk</b> Berkelium (247)	<b>Cf</b> Californium (251)	<b>Es</b> Einsteinium (252)	<b>Fm</b> Fermium (257)	<b>Md</b> Mendelevium (258)	<b>No</b> Nobelium (259)	<b>Lr</b> Lawrencium (262)

# Summary

- Entries in the periodic table tell us the number of protons, neutrons, and electrons there are in a neutral atom of each element
- The charge tells us how many electrons are added or missing in an ionized atom
- Isotopes are atoms of the same element with different numbers of neutrons

# Homework

- Read Ch. 4 (pp. 75-79, 86 – 90, 98 – 101)
- pp. 108 – 111; # 25, 27, 29, 33, 37, 75
- Handout on Mass Spectrometry
- Quiz on Tuesday (Discovery of the Atom and Mass Spec)